

Automated Horizontal Carrier 1.2 ton

AUTOPILOT
CDI120



Automated Horizontal Carrier

Truck specifications					CDI120
Identification	1.1	Manufacturer			Toyota
	1.2	Model			CDI120
	1.3	Drive			Electric
	1.4	Operator type			Automatic
	1.5	Load capacity/rated load	Q	kg	1200
	1.8	Load distance, load center to wheel center/turn center	x	mm	32
Weight	2.1	Service weight including battery according to 6.5		kg	332
	2.2	Axle load, with load, Drive/Front/Rear Castor wheel		kg	462/603/475
	2.3	Axle load, without load, Drive/Front/Rear Castor wheel		kg	164/90/78
Wheels	3.1	Drive/Castor			Polyurethane/Topthane®
	3.2	Wheel size, front		mm	2xØ80x38
	3.3	Wheel size, rear		mm	2xØ80x38
	3.4	Additional wheels (dimensions) drive wheel		mm	Ø200x50
	3.5	Wheels, number front/rear (x=driven wheels)			2x+1/1
	3.6	Track width, middle	b_{11}	mm	694
Dimensions	4.2	Height, lift table lowered	h_1	mm	529
	4.4	Lift movement	h_3	mm	32
	4.5	Height, lift table raised	h_2	mm	561
	4.6	Height charging contacts	h_4	mm	248
	4.7	Height charging arm top	h_5	mm	345
	4.19	Overall length	l_1	mm	1370
	4.20	Wheel center/turn center to rear cover length	l_2	mm	695
	4.21	Overall width	b_1	mm	812
	4.22	Overall width incl auto charging arm	b_2	mm	896
	4.23	EUR-pallet loadhandling attachment	$b_5/e/l$	mm	444/112/1212
	4.32	Ground clearance, centre of wheelbase	m_2	mm	15
4.35	Turning radius	W_a	mm	748	
Performance data	5.1	Travel speed, with/without load, forward direction/reverse direction		m/s	1.6/1.6, 1.6/0.3
	5.2	Lift speed, with/without load		mm/s	7.4/7.4
	5.3	Lowering speed, with/without load		mm/s	7.4/7.4
	5.7	Gradeability, with/without load		%	4/20
	5.10	Service brake			Electromagnetic
Electric motor	6.1	Drive motor rating S2 60 min		kW	0.63
	6.2	Lift motor rating S3 15%		kW	0.216
	6.4	Battery voltage, nominal capacity K_5 , Li-Ion		V/Ah	24/100
	6.5	Battery weight		kg	12.8
Other	8.1	Type of drive control			Variable AC
		Safety of laser products			Class 1 (IEC 60825-1)

n) = New value / text since previous version of the data sheet.

All data are based on table configuration. Other configurations may give other values.
 Truck performance and dimensions are nominal and subject to tolerances.
 Toyota Material Handling products and specifications are subject to change without notice.

Automated Horizontal Carrier

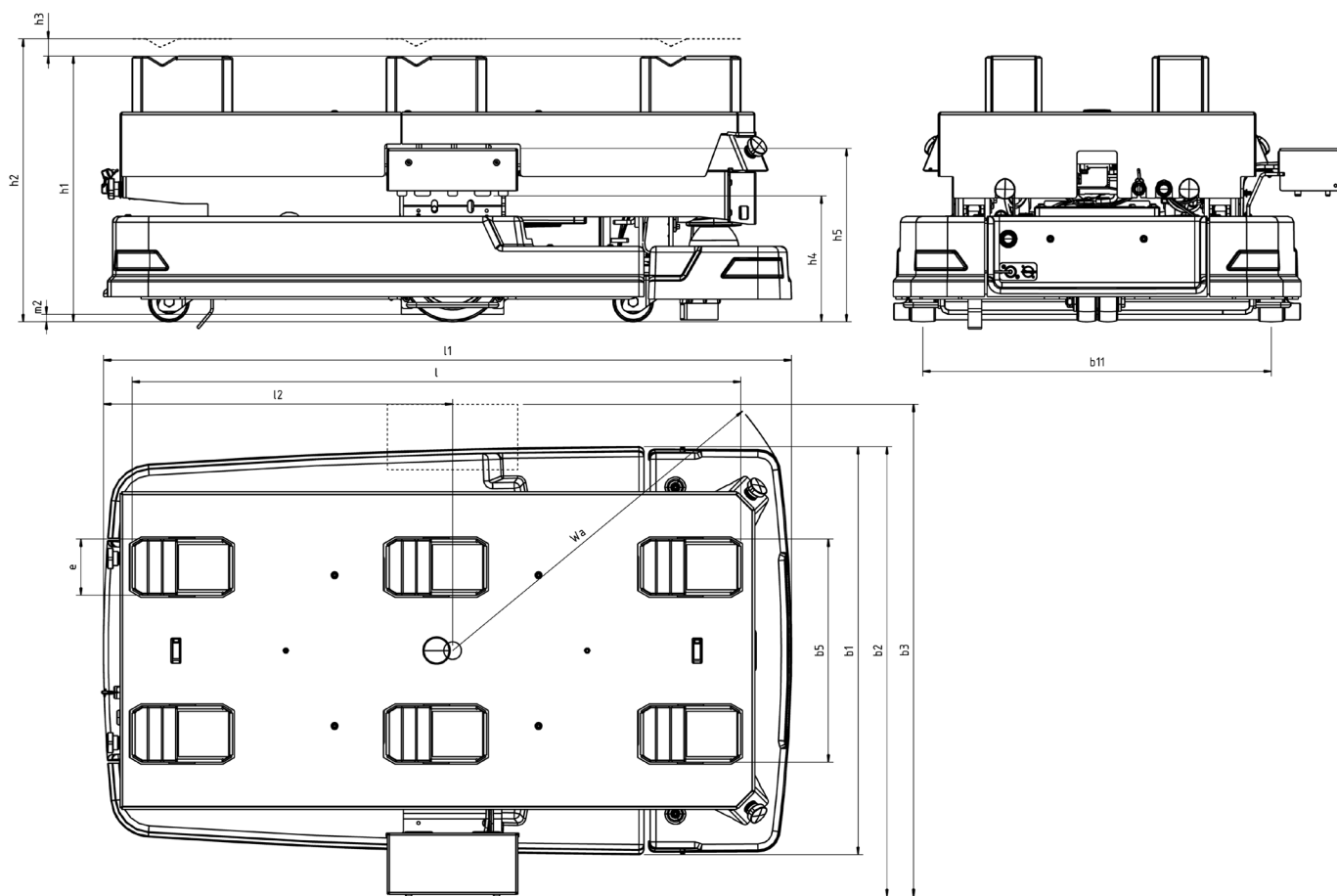

Pallet station

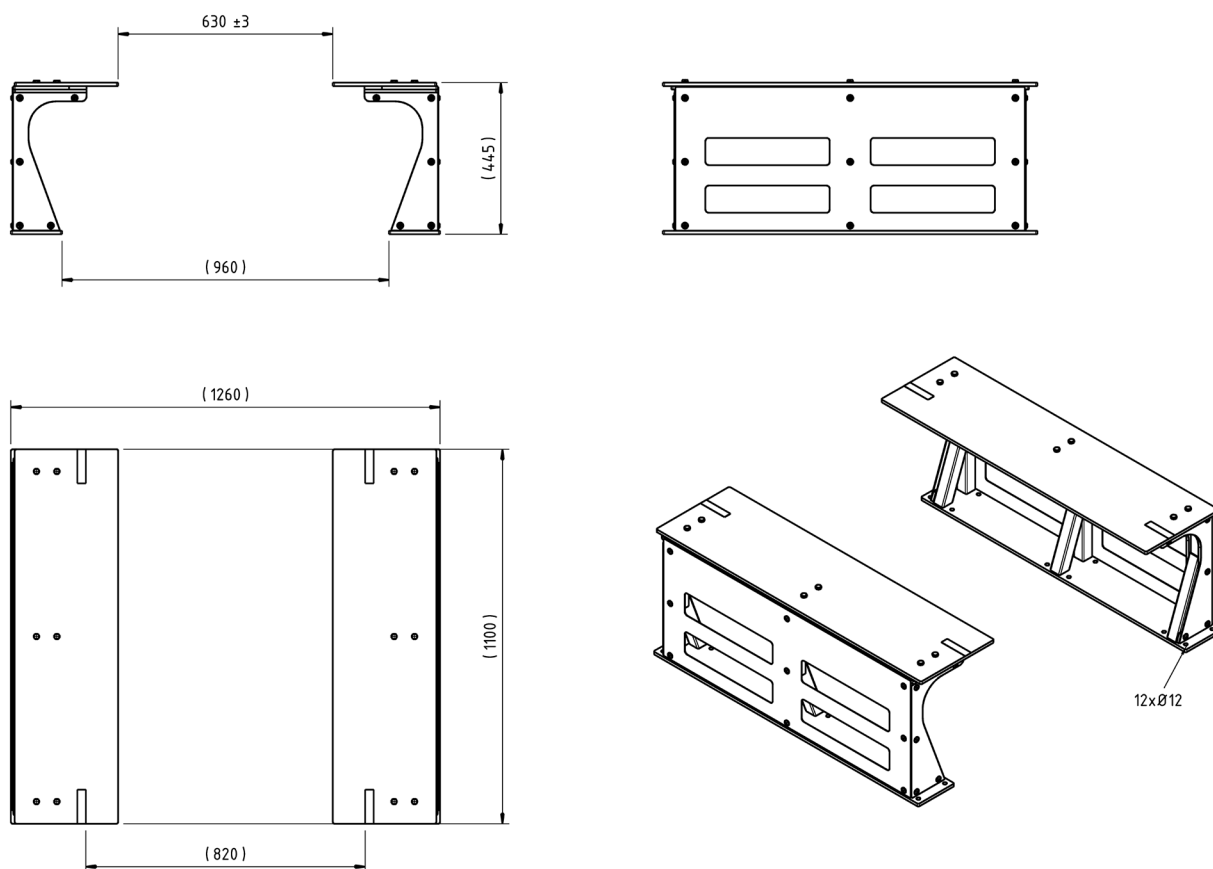

CDI120 features:

- Automatic
 - loading and unloading
 - horizontal transport
- Personal safety protection drive direction
- Auto charging Lithium Ion battery
- Blue LED warning light drive direction
- Load presence detection
- Pallet station

